

Design and Analysis of DC-DC Converter and Battery Charging Method in EV Dynamic Charging

Aisyaa Izzaty Razali^{1*}, Hassan Khalid¹, Marizan Mubin¹, and Saad Mekhilef²

¹Power Electronics and Renewable Energy Research Laboratory (PEARL), Department of Electrical Engineering, Universiti Malaya
50603 Kuala Lumpur, Malaysia

²School of Engineering at Swinburne University of Technology Australia
John St, Hawthorn VIC 3122, Australia

Corresponding e-mail: aisyaarazali@gmail.com

Abstract. Dynamic Wireless Power Transfer (DWPT) has advanced significantly, yet challenges remain, particularly with output pulsations in Electric Vehicles (EVs) during movement. Unlike Static Wireless Power Transfer (SWPT), which maintains a stable output voltage with high efficiency, DWPT experiences fluctuations due to rapid changes in mutual inductance between the transmitter and receiver coils during energy transmission. This paper addresses this issue by implementing a DC-DC converter and a control method for battery charging on the receiver side of the system. Conventional DC-DC converters were examined based on their performance, and the boost converter was selected for its high efficiency. The research progressed with the design of the boost converter, along with the Constant Current-Constant Voltage (CC-CV) control method, enhanced with a Proportional – Integral (PI) controller for battery charging, chosen for its simplicity. The complete system was modeled and simulated in a Simulink environment, followed by extensive testing under dynamic conditions reflective of real-world applications. The results demonstrate that the proposed system effectively reduces output voltage pulsations, keeping them below 0.1%, which is well within the acceptable range of 2%. Efficiency analysis revealed that the proposed system achieved an efficiency range of 96.6% to 99.5%, outperforming existing solutions in terms of efficiency.

Keywords. Electric vehicle (EV); Boost converter; Dynamic wireless power transfer (DWPT); Battery charging; Output pulsation.

1. Introduction

Electric vehicles (EVs) offer a practical option to tackle the energy problem and environmental deterioration by replacing conventional fuel-powered vehicles. Nevertheless, an existing challenge remains in the restricted driving distance of EVs, which requires frequent recharging. Regular recharging can become quite burdensome, as the tedious task of managing charger cables contributes to the overall inconvenience. To counter these inconveniences, wireless charging technology is becoming increasingly popular as a highly convenient alternative to traditional wired charging methods. It effectively eliminates the inconveniences typically associated with charger cables.

Static Wireless Power Transfer (SWPT) and Dynamic Wireless Power Transfer (DWPT) have received significant interest in the field of power electronics. However, SWPT demonstrates a limitation in mobility during charging process, requiring EVs to remain stationary at the charging stations until the

process is complete. Significantly, DWPT portrays itself as a superior choice, offering benefits such as reduced charging periods by allowing EVs to recharge while moving. This technological advancement signifies a transformative development in the field of EV research [1].

Even while DWPT is effective at extending the driving range of electric cars without requiring large battery installations, thereby contributing to cost savings, this road-powered technology faces a major challenge due to coils impairment [2]. This causes significant fluctuations in output voltage which are mainly caused by the changes in the mutual inductance and the load conditions, which interferes with the batteries charging process. Notably, the speed of the vehicle has the biggest impact on the pulse amplitude. Considering this, it becomes crucial to minimize the pulsations during the charging process, which involves varying speeds.

Numerous studies are now being conducted to propose solutions at both the structural level and control levels to effectively tackle this issue. Even though the compensation network and coil are very important for reducing output pulsations, the need of an extra DC-DC converter is crucial to make sure that the output voltage stays stable and the battery charges smoothly [3].

This paper proposes integrating DC-DC converters with an effective battery charging method that features a closed-loop feedback mechanism between the AC-DC rectifier and the power load, which is the EV battery. The DC-DC converter functions to further smooth the output voltage after the AC-DC rectification process. Since output pulsations pose significant challenges to battery charging efficiency, it is imperative to implement an effective charging method alongside the DC-DC converter. A well-designed battery charging approach is essential for enhancing voltage regulation. Figure 1 shows the integration of the proposed model, which consists of a DC-DC converter and a battery charge controller, into the receiving side of the EV DWPT system.

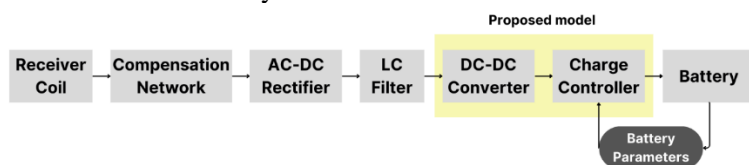

Figure 1: DWPT system (receiving side)

A buck-boost converter could potentially resolve the problem of limited power transfer in the single stage converters such as buck and boost converters. However, for instance, a single-switch buck-boost converter, according to the research by Yang et al., the reduction of pulsations of the output current and voltage can be achieved by implementing the Discrete Sliding Mode Control (DSMC) scheme [4]. This method is intricate and involves high-order control techniques.

Another buck-boost converter-based method of controlling is demonstrated by Zhang et al. which is an asynchronous control method. The dual buck-boost converter employs independent control of its two switches to minimize output pulsations. This is following that the conventional control method will result in losses and volatility [2]. This shows that the reduction of output variations in the buck-boost converter could only be possibly achieved by adopting complicated control strategies.

Another investigation on buck-boost converter was conducted in [5]. Their paper focused on the implementation of a cascaded buck and boost converter along with constant resistance control method. The proposed control technique avoids a divergence of the designed impedance matching system considering the load variation. This system introduced ripple voltage fluctuations thereby needed additional components such as lowpass filter.

When comparing the simpler topologies of DC-DC converters, specifically the buck and boost converters, in [6], a buck converter is used with an additional of an input capacitor. The paper focused on the Model Predictive Control (MPC) which its purpose is to do dynamic tracking to achieve dynamic performance.

Although better output power and efficiency has been achieved in this study, the control can be quite challenging for practical implementation in real-time applications.

A study by [7] implemented a Passivity-Based Controller (PBC) into the receiver side of the DWPT system, specifically with a buck converter. The primary objective of this work was to enhance efficiency and ensure a stable output current. The study not only successfully achieved its goals but also showcased rapid convergence to its operational point. However, it is worth noting that this type of control approach requires consideration of Euler-Lagrange (EL) and Port-Controlled Hamiltonian (PCH), which can add complexity to the design process.

In [8], the challenge of voltage output fluctuations can be addressed through the adoption of a two-phase receiver, coupled with the introduction of a cascaded bridgeless rectifier buck (CBRB) and a novel control method known as the Heuristic Current Ratio Control (HCRC). The integration of these topologies and methods has resulted in an enhancement in transfer efficiency. However, there exists an opportunity to further refine the heuristic current ratio method to pinpoint its optimal efficiency point.

Boost converters have been employed in applications beyond EVs, such as electric scooters, to regulate voltage output [9]. For EVs, there is a study conducted by Song et al. utilizing a Constant Resistance Control (CRC) approach on a boost converter to efficiently mitigate current stress. Nevertheless, it was noted that implementing the CRC led to larger fluctuations in the output. While the control technique enhances efficiency, but for a boost converter that provides low power transfer, it is accompanied by a significant downside of output voltage variations [10].

In [11], a modified boost converter is introduced by implying a charge-pump capacitor to regulate the output current ripples and capacitor-inductor-diode (CLD) cells to maintain its high voltage gain. This proposed topology has met its goals by minimizing the ripples and reducing losses and stresses, particularly across the switches, without requiring a significant increase in the duty ratio. Yet, it still requires further research to address the safety concerns associated with high-voltage floating ground applications, such as certain automotive setups.

Another study by [12] which its main goal is also to regulate the output voltage while minimizing intensive duty ratio. In this paper, a hybrid forward-boost converter is designed to operate in hybrid mode when the input is low while operating in its boost mode under normal conditions. This is also to mitigate the limitation of high voltage stress when the system is applied to a high duty cycle. This topology has successfully obtained improved efficiency than the conventional boost converter.

However, in [12], the use of mechanical switches was noted, leading to significant wear and tear losses, ultimately affecting efficiency. An improvement in design was introduced by [13], where the mechanical switch was replaced with power electronic switch to eliminate the manually switching control from the previous study. This modified converter was then applied in EV battery charging, incorporating a Constant Current - Constant Voltage (CC-CV) control strategy. The outcomes of this research showcase the effectiveness of the new EV charging approach.

To sum up, the mentioned papers exhibit drawbacks, stemming from their complex converter design and control methodology. These issues include limited efficacy in reducing output pulsations, lack of cost-effectiveness, and potential efficiency shortcomings. A research gap is identified as the boost converter, along with the CC-CV control method, has yet to be implemented in the dynamic charging of EVs. This paper fills this research gap by introducing a boost converter design paired with the CC-CV control method that aligns with criteria of simplicity, cost-effectiveness, and high efficiency.

This paper is arranged as follows, Section 2 presents the design of the proposed model, Section 3 presents the development of the DWPT system, Section 4 presents the simulation results, and Section 5 concludes the whole discussion.

2. Design of Proposed Model

2.1. Design of Boost Converter

The boost converter design implemented in this paper is based on the conventional boost converter topology as depicted in Figure 2. Several crucial factors guided this decision. Firstly, the conventional boost converter offers the advantage of simplicity, characterized by its minimal component count. Secondly, through the development and simulation of the entire DWPT system equipped with a conventionally designed boost converter, noteworthy observations were made. It was found that by utilizing the conventional boost converter topology alone, the desired voltage of 400V for both load usage and charging purposes could be reliably obtained.

This discovery eliminated the necessity for more complex boost converter designs, such as the high-gain boost converter, which might have resulted in excessive voltage stepping. Hence, the conventional boost converter design emerged as not only sufficient but also perfectly aligned with the project's goals of simplicity and cost-effectiveness.

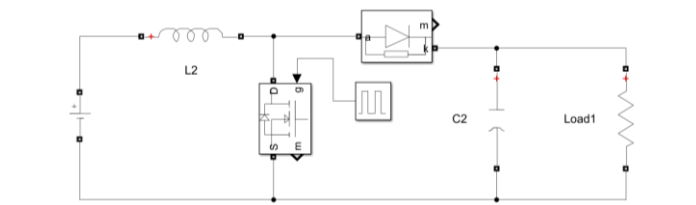

Figure 2: Boost converter design

2.2. Design of CC-CV control

The CC-CV control circuit, shown in Figure 3, regulates the EV battery charging process. It includes subsystems like the Current Controller, Voltage Controller, and feedback loops for precise control. The battery in this project has a 60-kWh capacity and a nominal voltage of 340V, allowing for approximately 175Ah. The maximum charging current is set at 76A.

The Current Controller maintains the desired current during the CC phase using a PI controller. It adjusts the current based on the battery's capacity and desired charging rate, comparing the actual current to the reference current and adjusting accordingly. The Voltage Controller manages the CV phase, also using a PI controller to regulate the voltage, set at 368.05V. It ensures the voltage stays at the desired level to fully charge the battery, preventing overcharging. Feedback loops continuously monitor current and voltage, ensuring deviations are corrected for efficient charging. After designing and testing the CC-CV control circuit independently, it was integrated into the complete DWPT system.

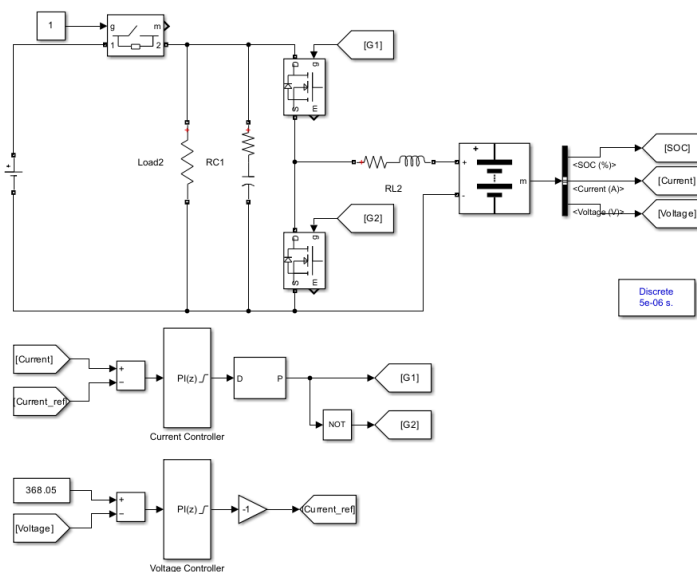

Figure 3: CC-CV control circuit design

3. Development of DWPT System

Figure 4 illustrates the DWPT system integrated with the proposed model, detailing both the transmission and receiver system. As can be seen, the proposed model is positioned between the LC filter and the EV battery within the receiver system. This system will be thoroughly examined in Section 4.1 to validate the functionality and performance of the proposed model.

Additionally, another model has been specifically designed for the receiver system of the DWPT system. Similarly, this model incorporates the proposed improvements, including the boost converter and the CC-CV control circuit. In this model, the power received from the receiver coil is represented by a DC voltage source. The value of this DC voltage source will be varied to simulate dynamic scenarios in the DWPT system, reflecting fluctuations in the power transferred from the transmitter coil to the receiver coil during the dynamic charging of EVs at various speeds. This is due to the voltage fluctuations at the receiver as the EVs pass through one transmitter to another [14].

Then, the system's capability to reject voltage pulsations caused by the power fluctuations will be analyzed in Section 4.2. Furthermore, this second model serves to simplify the efficiency analysis of the boost converter under varying duty cycles, reflecting the dynamic changes in the voltage supplied by the DC voltage source. Further discussion on this analysis will be provided in Section 4.3. Nevertheless, the design parameters for both models are similar as tabulated in Table 1.

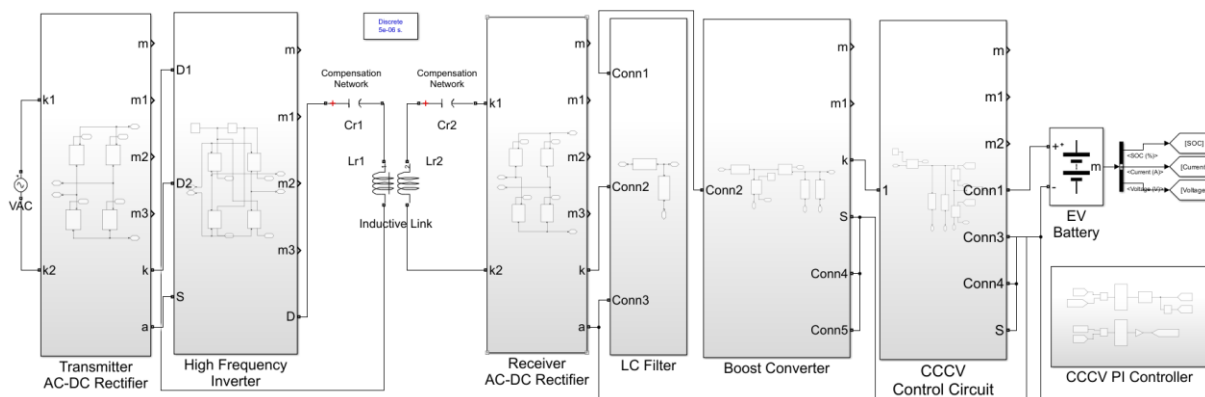

Figure 4: DWPT system with proposed model

Table 1: Design parameters of the proposed model

Parameter	Value	Parameter	Value
V_{AC}	240 V	V_{DC}	220 V
C_{r1} & C_{r2}	0.47	$Load_1$	100 Ω
L_{r1}	1.13112 μ H	$Load_2$	5 Ω
L_{r2}	3.142 μ H	RC_1	0.001 Ω
L_m	0.56556 μ H	RL_1	1000 μ F
L_1	5 mH	Nominal Voltage	0.05 Ω
C_1	220 μ F	Rated Capacity	576 μ F
L_2	15.625 μ H	Initial state-of-charge	340 V
C_2	1 mF	Battery response time	175 Ah
			30%
			1 s

4. Simulation Results

4.1. Comparison of DWPT System with and without Proposed Model

In this section, the performance of the DWPT system before and after the integration of the proposed model, comprising the boost converter and the CC-CV control circuit is observed. Figures 5 and 6 serve as visual representations of the output voltage characteristics under each scenario. When examining Figure 5, which depicts the DWPT system before the integration of the proposed model, significant fluctuations in the output voltage are observed. These fluctuations are indicative of poor voltage stability in the absence of the proposed model.

The voltage pulsation is measured at 23.637%. This high level of pulsation suggests that the system is unable to maintain a consistent output voltage, which is critical for efficient battery charging and load usage. The battery specifications utilized in this system are based on a nominal voltage of 340V. Therefore, the voltage expected to be provided to the load and battery is 400V.

Notably, the average output voltage recorded for this system before the integration of the proposed model is 207.3V, which falls short of meeting the desired voltage requirements for both load usage and battery charging purposes. This shortfall in voltage can lead to inefficient charging and potential damage to the battery over time.

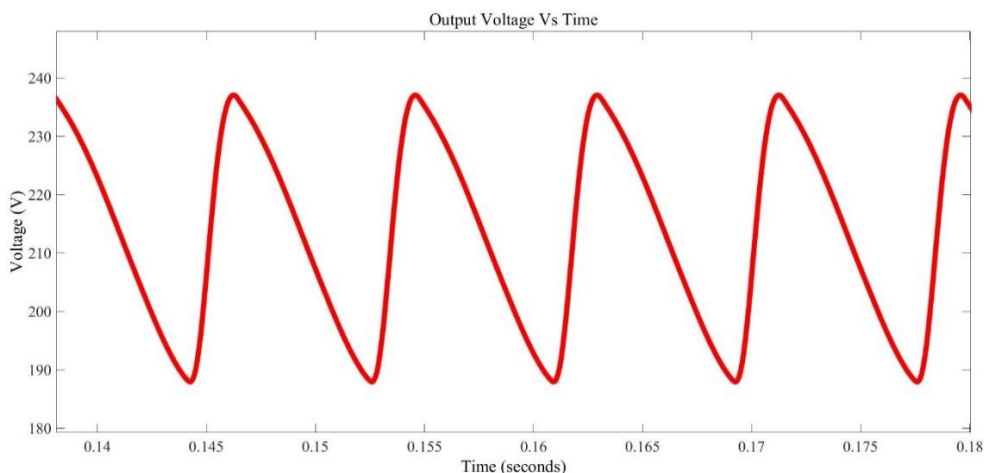

Figure 5: Output voltage without proposed model

Figure 6 shows the output voltage with the proposed model integrated into the DWPT system. The graph in Figure 6 illustrates two distinct voltage waveforms over time: the blue waveform represents the output voltage of the boost converter, while the green waveform shows the output voltage of the CC-CV control circuit.

Here, the boost converter has effectively stepped up the voltage to nearly 400V, thus satisfying the voltage demands for load usage and battery charging. The significant increase in voltage demonstrates the boost converter's capability to enhance the system's performance. Remarkably, the voltage pulsations are drastically reduced to a mere 0.533%, highlighting the effectiveness of the boost converter in mitigating voltage fluctuations. This is an impressive achievement, as the voltage pulsation is well within the acceptable range of 2%.

Furthermore, the integration of the CC-CV control circuit, along with a PI controller, further enhances voltage stability by minimizing pulsations to a negligible 0.027%. This control mechanism ensures that the battery receives a stable voltage, maintaining an average voltage of 362.1V. It can be seen that in this case, the PI controller requires further enhancement to achieve an output voltage closer to the desired 368.05V.

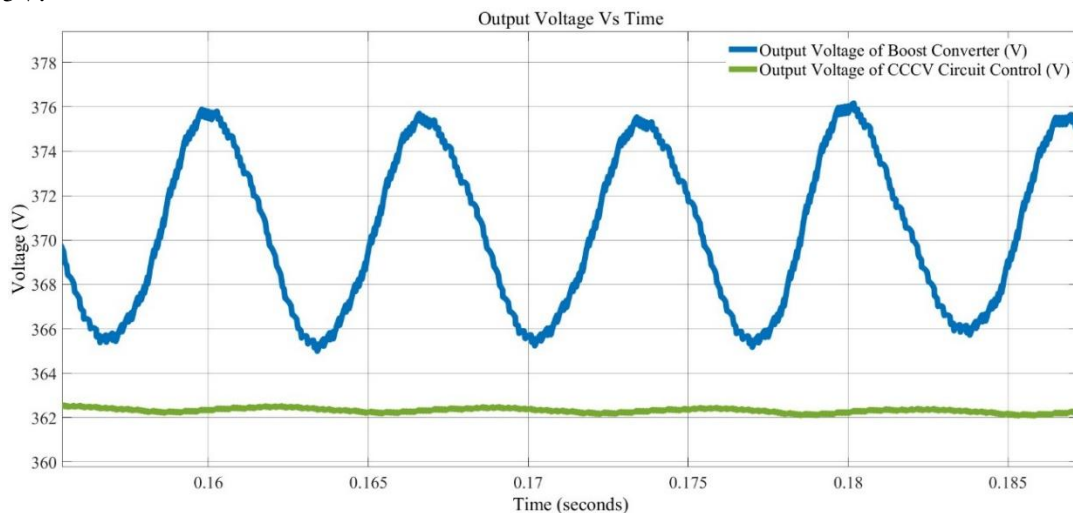

Figure 6: Output voltage with proposed model

The precision achieved by the control circuit prevents overvoltage conditions, which can be detrimental to battery health. Maintaining a safe desired voltage level during charging is paramount for preserving the integrity and efficiency of the battery. It not only protects against potential damage from overcharging, but also enhances charging performance to maximize energy storage and extend battery life.

Moreover, by minimizing voltage pulsations, thermal stress on the battery is effectively reduced, thereby extending its lifespan. The tendency of voltage fluctuations to generate heat can accelerate battery degradation, compromising its performance and longevity. The proposed model's ability to maintain a stable voltage output is therefore critical in ensuring the long-term reliability of the DWPT system.

4.2. Output Voltage Pulsation Rejection and Efficiency Analysis

In this section, two voltage measurement points are considered essential. The first measurement, referred to as the load voltage, is similar to the output voltage of the boost converter discussed in the previous section. This load voltage is intended to reach 400V to adequately power high voltage loads and charge the battery. The second measurement, representing the battery voltage, is taken between the CC-CV control circuit and the battery, also known as the output voltage of the CC-CV control circuit in the previous section. Ideally, this battery voltage should be 368.05V for safe charging.

These voltages were measured at different values from the DC source, reflecting the dynamic behavior of the charging system as the vehicle continuously moved on the charging lane. The DC voltage varied from 200 to 240V.

The first analysis, depicted in Figure 7, demonstrates the relationship between input voltage and the average output voltages for both the load and the battery. This analysis aims to observe the voltage level achieved, given the dynamic behavior in the energy transmission process between the coils in the system. The graph shows the input voltage on the x-axis, ranging from 200V to 240V, and the average voltage on the y-axis. Two lines are plotted: the blue line represents the load voltage, while the green line represents the battery voltage. As the input DC voltage increased, the load voltage also increased, starting at approximately 380V and reaching around 440V. In contrast, the battery voltage remained relatively constant, hovering close to the desired 368.05V across the entire range of input voltages.

This discrepancy in voltage behavior is attributed to the utilization of a PI controller in the CC-CV control circuit, which effectively maintained the battery voltage at the desired level. However, the boost converter lacked a similar control mechanism to regulate the load voltage at 400V, resulting in less precise voltage regulation. The absence of a control algorithm in the boost converter led to an increase in load voltage as the input voltage rose.

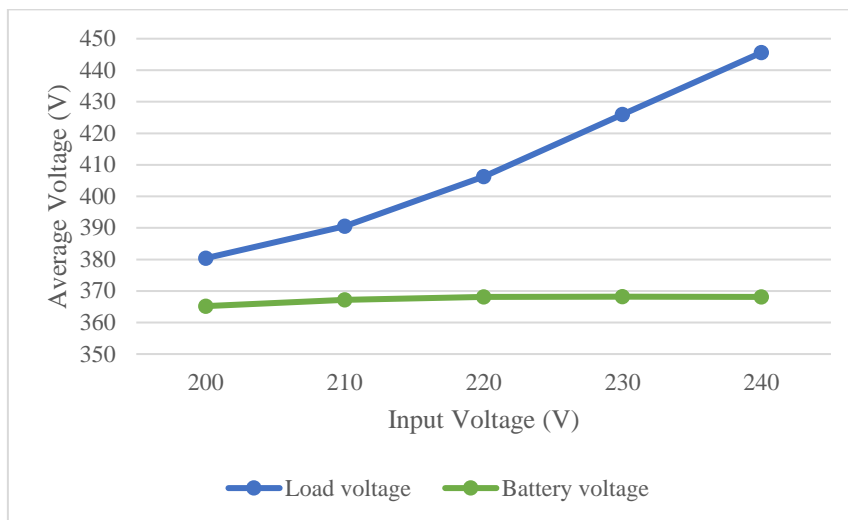

Figure 7: Average Output Voltage Vs Input Voltage

The results suggest that while the boost converter reduces voltage pulsations, there is potential for improving voltage regulation further. Hence, a future plan involves integrating advanced control algorithms like fuzzy logic into the boost converter. This step aims to enhance voltage regulation by dynamically adjusting the duty cycle.

The subsequent analysis, depicted in Figure 8, revealed the effectiveness of the boost converter and CC-CV control circuit in maintaining low voltage pulsations. The graph illustrates the relationship between input voltage (ranging from 200V to 240V on the x-axis) and voltage pulsation percentage (on the y-axis). Two lines are plotted: the blue line represents the load voltage pulsation, while the green line represents the battery voltage pulsation.

The blue line shows that the load voltage pulsation starts at approximately 1% when the input voltage is 200V and gradually decreases as the input voltage increases, reaching around 0.4% at 240V. This indicates that the boost converter effectively kept the load voltage pulsations below 1% across the entire input voltage range, demonstrating a significant improvement in voltage stability.

The green line represents the battery voltage pulsation, which remains consistently low, below 0.15%, throughout the input voltage range from 200V to 240V. This consistent reduction in battery voltage pulsations feeds a more stable power supply to the battery, helping to maintain battery health.

Compared to the DWPT system before the integration of the proposed model, where pulsations exceeded 20% (as shown in Figure 5), the proposed model has significantly improved the system's performance. The load voltage pulsations were maintained between 0.4% and 1%, while the battery voltage pulsations were consistently kept below 0.15%. This pronounced reduction in voltage pulsations highlights the effectiveness of the proposed model in improving voltage stability, especially in the dynamic EV wireless charging system.

These findings represent an exquisite improvement in the system's performance. The voltage pulsation remains within the acceptable range of 2% even after accounting for the dynamic behavior of the DWPT system. The synergy between the DC-DC converter and the CC-CV control circuit effectively mitigated pulsations before they reached the battery which is a promising development for the longevity of the battery's life cycle.

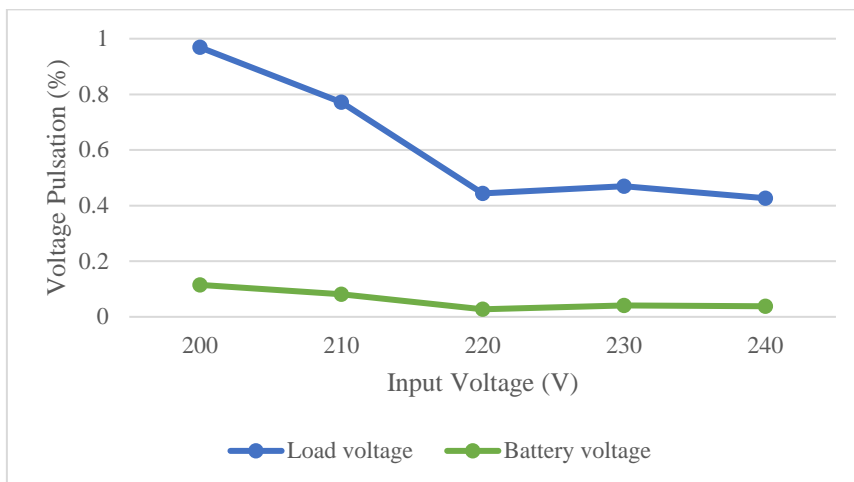

Figure 8: Output Voltage Pulsation Vs Input Voltage

Next, the efficiency analysis of the proposed model is conducted, which is an essential aspect in evaluating its overall performance. Efficiency is determined by subtracting the losses associated with diodes, switches, and inductors. Throughout the analysis, a fixed input voltage of 220V is maintained, while the duty cycle is adjusted between 0.125 and 0.875. The power loss across each component is calculated subsequently summarized in Table 2. The overall efficiency of the proposed model across various duty cycles is illustrated in Figure 9.

The efficiency shown by the proposed model proves satisfactory, ranging from 96.6% to 99.5%. However, it is noted that as the duty cycle increases, efficiency tends to decline due to rising losses. The predominant source of loss within the model is attributed to switching and conduction losses from the MOSFET, alongside an additional contribution from the inductor's DC resistance.

By carefully selecting the switching frequency and components, it is possible to minimize these losses. For instance, using MOSFETs with lower on-resistance and optimizing the inductor design can help reduce conduction and resistive losses. Additionally, selecting an appropriate switching frequency can balance the trade-off between switching losses and conduction losses.

Table 2: Efficiency for proposed model

	P_{con} (W)	P_{sw} (W)	P_{VF} (W)	$P_{inductor}$ (W)	P_{out} (W)	Total P_{loss} (W)	η (%)
D = 0.125	0.221	10.473	13.578	0.857	5157.441	25.130	99.515
D = 0.25	0.812	18.822	15.888	1.643	6985.449	37.166	99.471
D = 0.375	2.550	33.752	19.284	3.499	10265.62	59.085	99.428
D = 0.5	8.228	63.986	24.066	9.086	15952.04	105.366	99.344
D = 0.625	28.713	131.433	31.896	26.504	27994.68	218.546	99.225
D = 0.75	169.317	371.376	47.064	128.451	60949.25	716.208	98.839
D = 0.875	1403.758	998.823	59.16	883.976	96255.72	3345.717	96.641

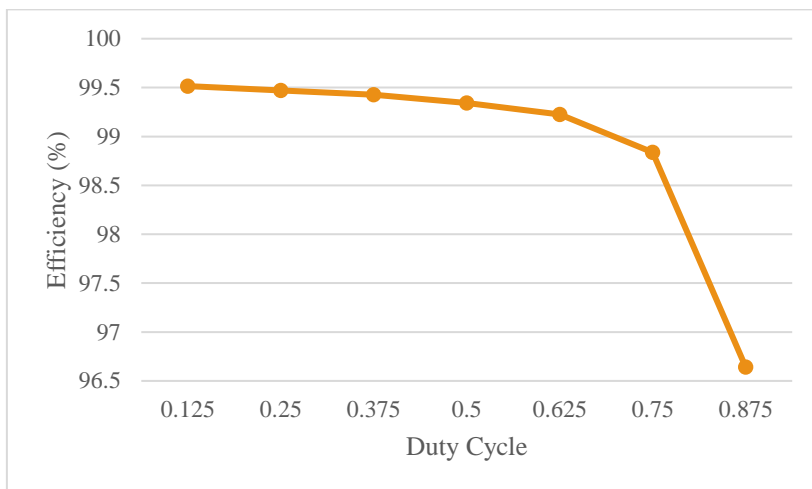

Figure 9: Efficiency Vs Duty Cycle for proposed model

Nevertheless, the achieved efficiency is sufficiently good, demonstrating the effectiveness of the proposed model design. The high efficiency across a wide range of duty cycles indicates that the model is well-suited for applications requiring dynamic power management and high efficiency, such as EV battery charging systems.

4.3. Comparison of Proposed Model with Existing Solutions

Table 3 provides an all-inclusive comparison between the proposed model in this paper and previously developed DWPT systems. The table includes various publications that utilize different DC-DC converter topologies and control strategies, along with their respective efficiency ranges, estimated cost and the number of passive components.

The efficiency of the proposed model is on par with or better than the previously developed systems. However, existing studies reported efficiencies exclusively from experimental testing, except for [4]. To ensure equity, the efficiency of the proposed model will be compared to that of the system proposed by [4]. In their study, a complex control strategy, DSMC, is utilized, resulting in an efficiency range of only 62% to 68% based on simulation. Such sophisticated approaches often lead to increased conduction losses and system complexity, thereby reducing efficiency.

In contrast, the proposed model employs a simpler PWM control strategy, yet it achieves a greater efficiency range of 96.6% to 99.5%. Therefore, even with a simpler control method, it is evident that the proposed model has significantly surpassed and outperformed the efficiency reported by [4].

Moreover, the proposed model’s simpler control strategy likely results in lower conduction losses compared to the previous topologies that require complex controllers for MOSFET switching. This simplicity not only enhances efficiency but also reduces the number of passive components required, thus the overall cost. For instance, the estimated cost of the proposed model ranges from RM 100 to 213, which is lower than that of systems presented by [11] and [12], both of which employ a similar type of converter. Additionally, the proposed model uses fewer passive components, further contributing to its cost-effectiveness and ease of implementation.

In summary, the proposed model demonstrates superior performance in terms of efficiency, cost-effectiveness, and simplicity compared to existing solutions. The high efficiency range of 96.6% to 99.5%, combined with the lower estimated cost and reduced number of passive components, highlights the advantages of the proposed model. This makes it a competitive solution for DWPT applications.

Table 3: Comparison of the proposed model with existing solutions

No.	Publication	DC-DC Converter Topology	Control Strategy	Efficiency, η (%)	Estimated Cost (RM)	No. of Passive Components
1.	Zhang, et al. [2]	Buck-boost	Asynchronous Control	$84 < \eta < 95.57$	300 - 600	16 - 20
2.	Yang, et al. [4]	Buck-boost	DSMC	$62 < \eta < 68$	250 - 450	15 - 18
3.	Zhou, et al. [6]	Buck	MPC	Maximum at 92	180 - 350	12 - 17
4.	Jiang, et al. [8]	Buck	HCRC	$90.5 < \eta < 91.5$	220 - 450	13 - 16
5.	Malik, et al. [11]	Boost	Additional charge-pump capacitor and CLD cells	$83.29 < \eta < 93.97$	150 - 300	11 - 15
6.	Joseph, et al. [12]	Boost	Hybrid forward-boost converter	Maximum at 95.4	200 - 400	13 - 18
7.	Proposed model	Boost	CC-CV	$96.6 < \eta < 99.5$	100 - 213	11-13

5. Conclusion

This paper addresses the challenge of output pulsations in DWPT systems for EVs while they are in motion. By integrating a novel combination of a boost converter and CC-CV control method for battery charging on the receiver side, the issues have been effectively mitigated.

The proposed system showcased exceptional voltage pulsation rejection capabilities, achieving a pronounced reduction from over 20% in the initial system to less than 1% post-integration. With the boost converter, voltage pulsations were significantly reduced and maintained within a range of 1% to 0.4%. Furthermore, the integration of the CC-CV control circuit, enhanced by a PI controller, further enhanced voltage stability by minimizing pulsations to negligible levels, below 0.15%. The performance of this system is outstanding as the voltage pulsation remains comfortably within the acceptable range of 2%. Additionally, the proposed system achieved excellent efficiency ranging from 96.6% to 99.5%, surpassing existing solutions in both efficiency and simplicity. Despite existing research on boost converters paired with CC-CV control methods, this paper fills a critical gap identified in the literature by implementing and testing these solutions in DWPT systems.

In closing, the paper has successfully developed a system comprising a DC-DC converter and a battery charging control method that is the most efficient, simplest, and cost-effective solution for rejecting voltage output pulsations in EV dynamic charging.

References

- [1] X. Hu, Y. Wang, Y. Jiang, W. Lei and X. Dong, "Maximum Efficiency Tracking for Dynamic Wireless Power Transfer System Using LCC Compensation Topology," in *2018 IEEE Energy Conversion Congress and Exposition (ECCE)*, Portland, OR, USA, 2018.
- [2] Q. Zhang, X. Zhang, W. Li, T. Hu, Y. Wang and S. Shen, "New Control Method for Receiver-Side DC-DC Converter With Large Stability Margin and Fluctuation Suppression Toward DWPT System," *IEEE Transactions on Industrial Electronics*, pp. 7944-7954, 2023.
- [3] R. Singh, S. K. Gawre and G. Dyanamina, "Review and Analysis of DC-DC Power Converter Performance for Fast Charging of EVs," in *2021 IEEE 2nd International Conference On Electrical Power and Energy Systems (ICEPES)*, Bhopal, India, 2021.
- [4] Y. Yang, W. Zhong, S. Kiratipongvoot, S.-C. Tan and S. Y. R. Hui, "Dynamic Improvement of Series-Series Compensated Wireless Power Transfer Systems Using Discrete Sliding Mode Control," *IEEE Transactions on Power Electronics*, pp. 6351-6360, 2018.
- [5] K. Colak, M. Bojarski, E. Asa and D. Czarkowski, "A constant resistance analysis and control of cascaded buck and boost converter for wireless EV chargers," in *2015 IEEE Applied Power Electronics Conference and Exposition (APEC)*, Charlotte, NC, USA, 2015.
- [6] Z. Zhou, L. Zhang, Z. Liu, Q. Chen, R. Long and H. Su, "Model Predictive Control for the Receiving-Side DC-DC Converter of Dynamic Wireless Power Transfer," *IEEE Transactions on Power Electronics*, pp. 8985-8997, 2020.
- [7] W. Chen, Q. Chen, L. Zhang and R. Long, "Passivity-Based Controller of Dynamic Wireless Power Transfer System," in *2019 34rd Youth Academic Annual Conference of Chinese Association of Automation (YAC)*, Jinzhou, China, 2019.
- [8] J. Jiang, Z. Li, K. Song, B. Song, S. Dong and C. Zhu, "A Cascaded Topology and Control Method for Two-Phase Receivers of Dynamic Wireless Power Transfer Systems," *IEEE Access*, pp. 47445-47455, 2020.
- [9] Y.-C. Hsu, S.-C. Kao, C.-Y. Ho, P.-H. Jhou, M.-Z. Lu and C.-M. Liaw, "On an Electric Scooter With G2V/V2H/V2G and Energy Harvesting Functions," *IEEE Transactions on Power Electronics*, pp. 6910-6925, 2018.
- [10] S. Song, S. Dong and Q. Zhang, "Receiver Current-Stress Mitigation for a Dynamic Wireless Charging System Employing Constant Resistance Control," *IEEE Transactions on Power Electronics*, pp. 3883-3893, 2021.
- [11] M. Z. Malik, H. Chen, M. S. Nazir, I. A. Khan, A. N. Abdalla, A. Ali and W. Chen, "A New Efficient Step-Up Boost Converter with CLD Cell for Electric Vehicle and New Energy Systems," *Energies*, 2020.
- [12] P. K. Joseph and E. Devaraj, "Design of Hybrid Forward Boost Converter for Renewable Energy Powered Electric Vehicle Charging Applications," *IET Power Electronics*, 2019.
- [13] D. David, N. K. K. M. K. U. Mansoor, "Modified Hybrid DC-DC Converter for EV Charging Applications," in *2023 International Conference on Innovations in Engineering and Technology (ICIET)*, Muvattupuzha, India, 2023.
- [14] M. Lu, M. Bagheri, A. Khamitov and B. Alimkhanuly, "Experimental Analysis of the Voltage Pulsations at the Receiver's Side of a Dynamic Wireless Charging System for Electric Vehicles," in *2018 IEEE 8th Power India International Conference (PIICON)*, 2018.